



PROFESSIONAL SHOW LIGHTING

TIGER SCAN

HMI 575
HMI 1200

INSTRUCTION MANUAL

IMPORTANT: Read carefully. It is essential for the correct and safe use of the equipment that erectors and operators should be fully conversant with the information and instructions given in this manual.

1 INSTALLING THE PROJECTOR

• Unpacking

Open the box, remove the projector from the packing and place it on a flat, horizontal surface.

Unpack the standard accessories supplied with the equipment. Inspect the lamp change label (1) and replace it with one of the optional language versions if necessary.

Make certain that the label is never removed, as it displays important safety information.

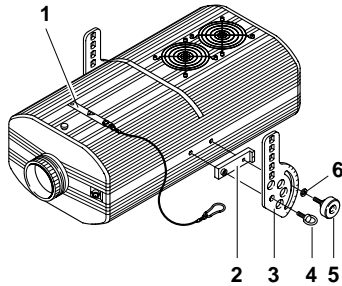

• Initial assembly operations

Position block (2) on the projector body so that it is aligned with the threaded holes; secure graduated plate (3) with eyebolt (4) and then fit knob (5) and washer (6).

Position bracket (7) on graduated plate (3) at the desired height; insert bushing (8), chamfered washer (9) and screw (10) in the selected hole and tighten using the supplied Allen key.

The bracket (7) can also be fitted on the underside of the projector by inverting the position of graduated plate (3).

If the projector has been shipped with plate (3) already fitted, before removing the plate (if necessary) remove the safety bolt located inside the fixture in correspondence with eyebolt (4).

Set the projector support in the desired position and secure by tightening knobs (5).

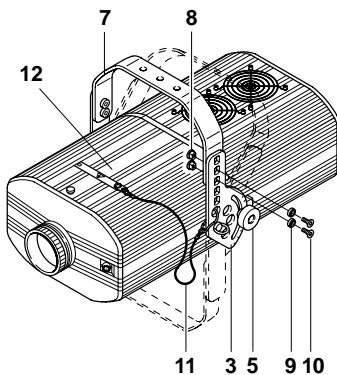

Fasten the safety wire (11) of lamp change cover (12) to graduated plate (3).

• Fitting the lamp

Refer to directions for replacement of the lamp given under heading 7 MAINTENANCE.

• Installing the projector

The projector can be mounted in any position without its operating characteristics being affected.

IMPORTANT: fix the projector in the desired position utilizing the holes in the bracket (7). Secure preferably using two $\varnothing 12$ bolts with nuts and lock washers.

Make certain that the anchorage is stable before positioning the projector.

• Fitting the safety wire

A safety wire (15) is supplied for use with the HMI 1200 version. The wire must be secured to the gantry or other structure and then anchored to the eyebolts (4) on the projector itself.

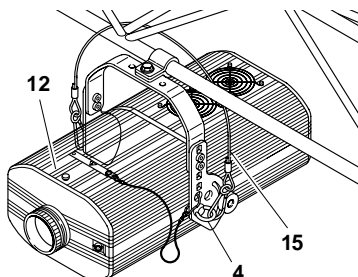

IMPORTANT: the safety wire must be secured to the projector and to the supporting structure in such a way that if the bracket should fail, the projector will fall as short a distance as possible. Following any such failure, the safety wire must be replaced with a genuine Clay Paky spare.

• Minimum distance from target objects

The projector must be positioned in such a way that objects struck by the beam are separated from the lens at least by the distance indicated on the lamp change label against the symbol shown alongside.

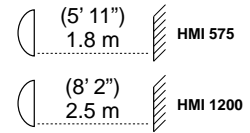

• Minimum distance of inflammable materials from any part of the equipment: 0.10 m (4") for HMI 1200, 0.07 m (3") for HMI 575.



The projector may be mounted on surfaces rated normally inflammable.

IMPORTANT: For better and more reliable operation of the projector, the ambient temperature must not exceed 35° C (95° F). Protection factor IP 20: the appliance is protected against penetration of solid bodies more than 12mm (0.5") in diameter (first digit 2), but can be damaged by spray, jet, drip or rain water (second digit 0).

2 INSTALLING THE MIRROR HEAD

• Unpacking

Open the box, take out the mirror head, position it on a horizontal surface and remove the elastic transit bands (16) from the tilt motor.

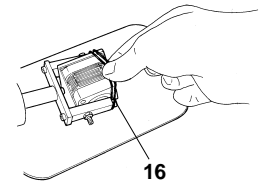

• Fitting the mirror head

Fit the mirror head (17) to the projector and secure with the three knobs (18). Connect the mirror head plug (19) to the socket (20) located on the front of the projector.

Connect the metal safety wire (21) to the tag (22) on the projector.

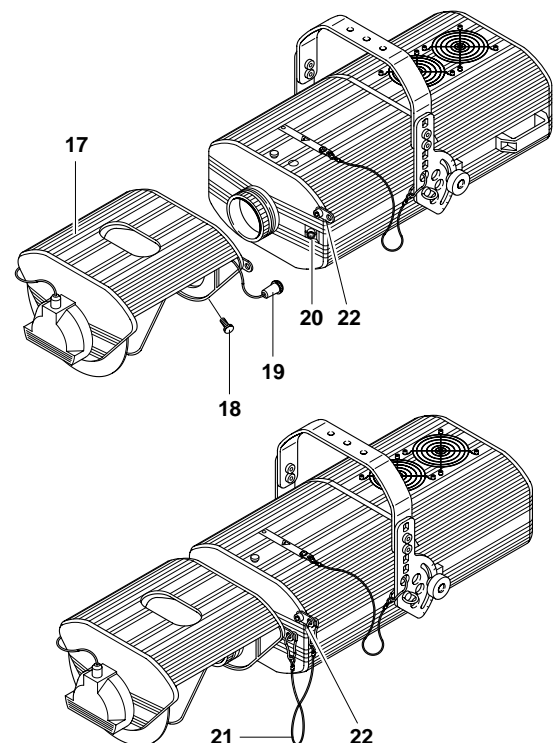

3 POWER SUPPLY AND INTERFACE

• Connecting to the electrical power supply

The operations described in this heading must be carried out by a licensed electrician.

It is good policy to connect projectors to the power supply by way of dedicated switches, so that each can be turned on and off individually from a remote station.

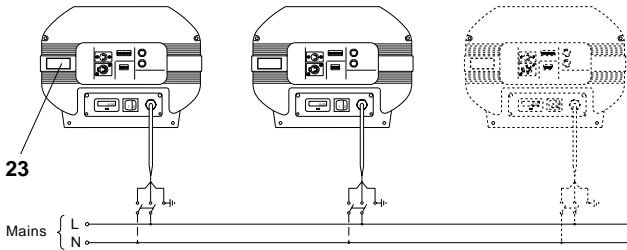

The projector is designed to operate at the voltage and frequency indicated on the electrical data plate (23) affixed to the rear end.

Check that these two values correspond to the mains voltage and frequency.

IMPORTANT: the projector must be connected to a power supply circuit having a proper earth system (Class I appliance).

• Connecting the control signals

0-10V CONNECTION

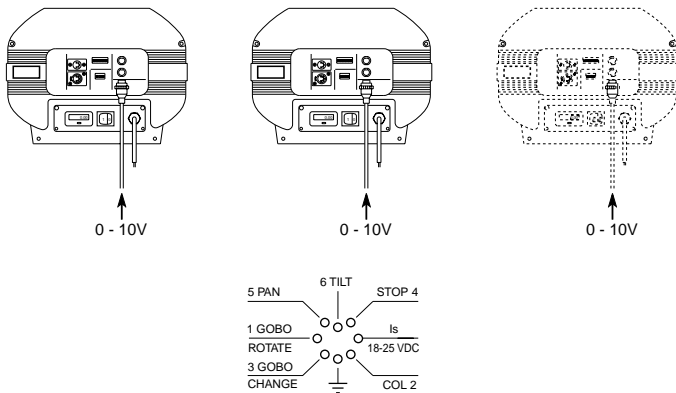

The connection between controller and projector must be made using a multicore cable with 8 wires of 0.25mm² section and a DIN 8 PIN 45° plug/socket connector.

RS 232/423(PMX) - DMX 512 CONNECTION

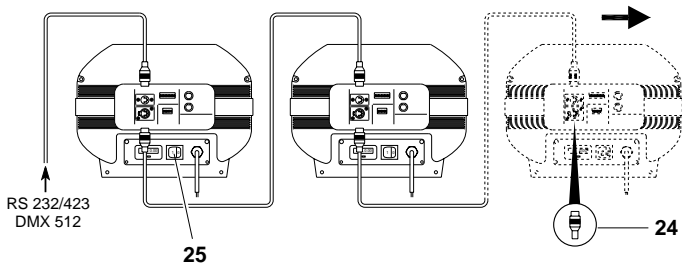

Projectors are wired up to the controller and one to the next using two-core screened cable and Cannon 5 pin XLR type plug/socket connectors.

To connect a DMX line, a terminating plug (24) with a 100Ω resistor wired between pins 2 and 3 must be fitted to the last projector connected in series; the plug is not required when using an RS232/423(PMX) signal.

The wires must not come into contact with each other or with the metal casing of the plug.

The casing of the plug/socket must be connected to the screen and to pin 1 of the connectors.



Having completed the operations described above, press the on/off switch (25). Check that the lamp comes on and that the auto-reset sequence starts.

• Projector address codes (for digital signals)

Each TIGER SCAN projector uses 6 control channels. To ensure that different projectors are addressed correctly by the controller, a code must be assigned to each one. This operation is carried out on each TIGER SCAN by setting the microswitches as indicated in the table below.

Spotlight selection

CODE	1	2	4	8	16	32	64	128	256	TEST
Projector 1 - Channels 1-6	ON	▲	▼	▼	▼	▼	▼	▼	▼	▼
Projector 2 - Channels 7-12	ON	▲	▲	▼	▼	▼	▼	▼	▼	▼
Projector 3 - Channels 13-18	ON	OFF	▼	▼	▼	▼	▼	▼	▼	▼
Projector 4 - Channels 19-24	ON	OFF	▲	▼	▼	▼	▼	▼	▼	▼
Projector 5 - Channels 25-30	ON	OFF	▼	▲	▼	▼	▼	▼	▼	▼
Projector 6 - Channels 31-36	ON	OFF	▲	▲	▼	▼	▼	▼	▼	▼
Projector 7 - Channels 37-42	ON	OFF	▲	▼	▼	▼	▼	▼	▼	▼
Projector 8 - Channels 43-48	ON	OFF	▲	▲	▼	▼	▼	▼	▼	▼
Projector 9 - Channels 49-54	ON	OFF	▼	▼	▲	▼	▼	▼	▼	▼
Projector 10 - Channels 55-60	ON	OFF	▲	▼	▼	▲	▼	▼	▼	▼
	ON	OFF								▼

Setting the TEST switch to the ON position for a few seconds with the projector powered-up, an auto-reset routine is carried out. Leaving the TEST switch at the ON position for a longer period, a full self-test program will be completed; once the operation has terminated, return the switch to the OFF position.

4 POSITIONING THE PROJECTOR

• Alignment procedure

Before positioning the projector, set the channels as shown in the following table:

CHANNEL	SLIDER POSITION
1 GOBO ROTATION	-
2 COLOUR WHEEL	-
3 GOBO SELECTION	-
4 DIMMER/STOPPER/STROBE	100 % (white beam)
5 PAN	50%
6 TILT	50%

After setting up the channels loosen the knobs (5), and manoeuvre the projector on its bracket (7) until the beam is directed at the centre of the scene, then retighten the knobs (5).

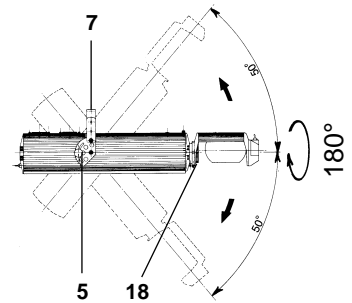

• Adjusting the mirror head

The beam can be positioned not only by moving the entire projector, but also by adjusting the mirror head.

To do this, loosen the three knobs (18), turn the mirror head to the desired position, and retighten the knobs.

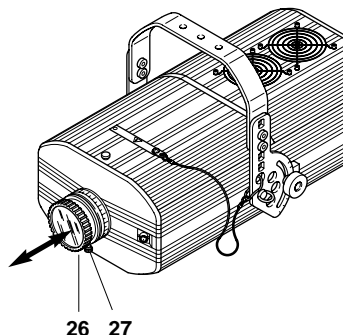

• Adjusting the lens

Move the lens (26) back and forward until the projected image is satisfactorily focused, then tighten the knob (27).

5

CHANNEL FUNCTIONS

CANNEL	FUNCTION
1	GOBO ROTATION
2	COLOUR WHEEL
3	GOBO SELECTION
4	DIMMER/STOPPER/STROBE
5	PAN
6	TILT

• GOBO ROTATION - channel 1

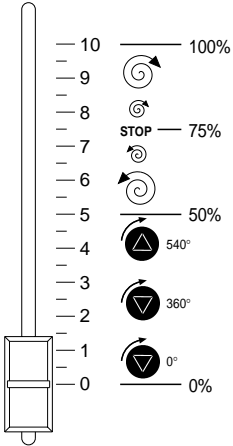

From 0% to 49.7% the gobo rotates through 540° (1 1/2 turns).
 From 50% to 75% the gobo rotates more quickly at first and then slows down to a complete stop.
 From 75.5% to 100% the gobo begins turning in the opposite direction, slowly at first and then gradually faster.

• COLOUR WHEEL - channel 2

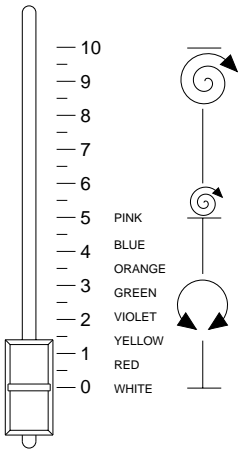

In the 0% to 50% range of adjustment the colour change in response to movement of the potentiometer is linear and continuous so that the slider can be stopped in intermediate positions to obtain a two-colour beam.
 From 50% to 100% the wheel rotates continuously with speed increasing steadily from 0 to 300 rpm.

• GOBO SELECTION - channel 3

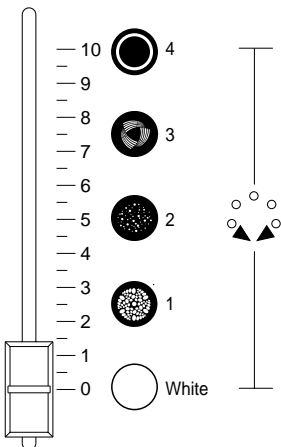

The change occurs instantaneously as the slider reaches different preset levels on the graduated scale.

• DIMMER/STOPPER/STROBE - channel 4

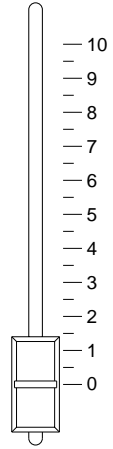

In the 0% to 50% range of adjustment, the dimmer opens gradually to maximum aperture.
 Strobe effect is produced from 54.7% to 95%, with frequency increasing from 1 to 7 flashes/second.
 The aperture remains fixed between 95% and 100% of the range.

• PAN - channel 5

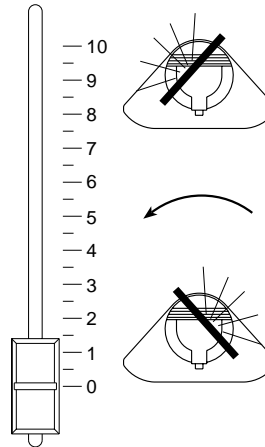

Horizontal movement (Pan) of the mirror occurs gradually as the slider is advanced. From the zero position mirror movement is linear and continuous up to the opposite end of travel. The mirror can be stopped at any intermediate angle.

• TILT - channel 6

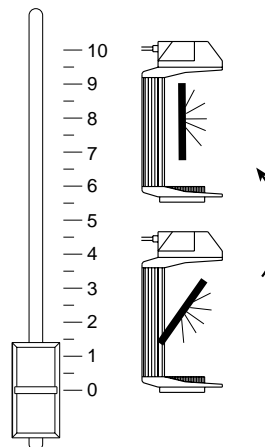

Vertical movement (Tilt) of the mirror occurs gradually as the slider is advanced. From the zero position mirror movement is linear and continuous up to the opposite end of travel. The mirror can be stopped at any intermediate angle.

GRAPHS SHOWING BEAM DATA AND ILLUMINATION VALUES

Standard Objective 1:2,5 / 250

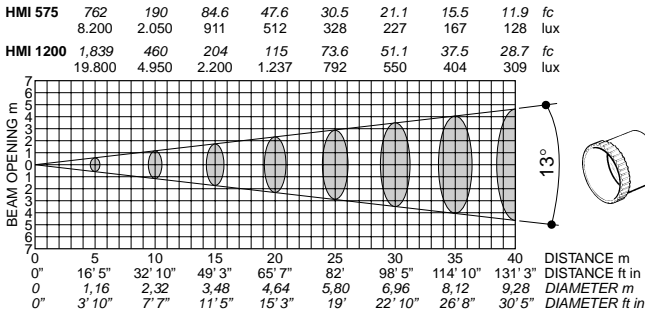

Objective 1:3 / 150 wideangle

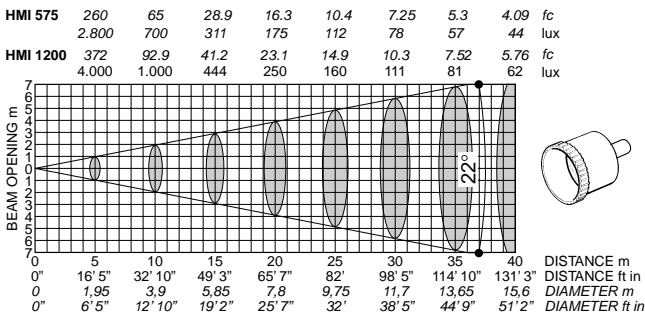

IMPORTANT: isolate the projector from the electrical power supply before commencing maintenance work of any description. The maximum temperature on the outer surface of the projector under normal operating conditions is shown on the lamp change label. After switching off, do not remove any part of the projector for the time indicated on the lamp change label (1).

Once this time has elapsed, the risk of a lamp exploding is practically zero. If the lamp needs changing, wait a further 20 minutes to avoid the risk of burns. In the event of a lamp exploding, the appliance is designed to prevent fragments of glass from being scattered. The lenses supplied with the appliance must be fitted at all times, and if visibly damaged, must be replaced with genuine spares.

• Opening the projector

Loosen the knob (28) and remove the lamp access cover (12). Once the necessary work has been completed, refit the cover (12) and tighten the knob (28).

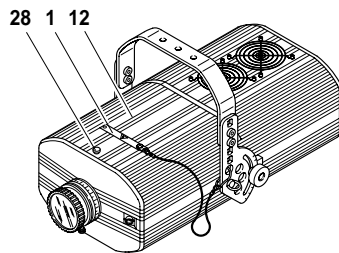

• Changing the lamp

Open the projector, loosen the two side nuts (29) of the lamp to be changed and remove it from the supports (30). Remove the new lamp from its box, loosen the two side nuts (29) and locate the lamp in the supports (30). Finally, retighten the nuts.

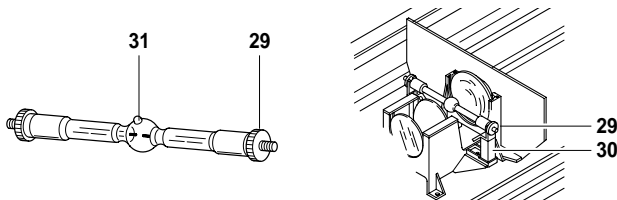

IMPORTANT: for uniform distribution of the light beam, the lamp must be positioned so that the glass pip (31) on the bulb does not coincide with the optical axis of the projector. With this in mind, locate the pip as high up as possible.

CAUTION: The projector uses a high pressure discharge lamp with external starter.

- When fitting a new lamp, read the manufacturer's instructions carefully.
- The lamp must always be changed without delay if damaged or deformed by heat.

• Changing the colour filters

Having opened the projector, identify the filter to be changed, grip firmly between thumb and forefinger and push against the spring clip (32) until free of the fixed clips (33). Bend the filter outwards and remove. Offer the new filter to the spring clip (32) and anchor behind the two fixed clips (33).

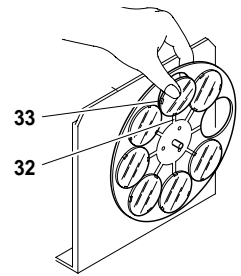

• Changing metal gobos

Having opened the projector, identify the gobo to be replaced and push gently toward the clips (34) until free. Take the selected replacement from the holder (35) on the dimmer/stopper/strobe plate. Offer the new gobo to two clips, push gently and locate behind the remaining clips, checking for flatness.

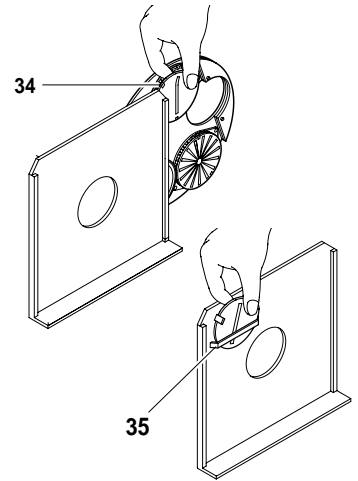

• Routine cleaning

To maintain the light output of the projector undiminished, parts that tend to accumulate dust and grease must be cleaned periodically. In most circumstances, the projector will give long and trouble-free service if these simple guidelines are followed. To remove dirt from the lenses and filters, use a soft cloth moistened with any liquid detergent suitable for cleaning glass.

IMPORTANT: do not use solvents or alcohol

- Parts that need cleaning frequently.
- Parts that need cleaning monthly.

Use a soft brush to clean the gobo wheel whenever necessary. Internal components should also be given a general clean once a year, dislodging dust and dirt with a brush and removing it simultaneously with a vacuum cleaner.

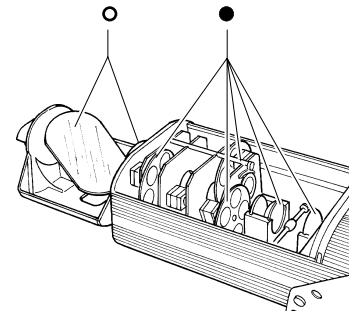

• Lubrication

To ensure that the rotating gobos continue to operate smoothly, the bearings should be lubricated with oil every six months: use only Kernite LUBE K AHT (p/n 164028/801). Apply the oil using a syringe with a fine needle.

Avoid over-lubricating, as excess oil could be spattered during rotation.

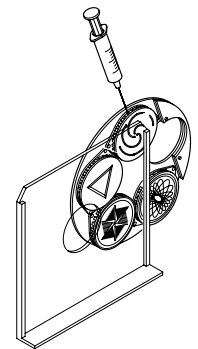

• Lubrication of mirror head clutches

Check periodically that the grease applied to the mirror pan and tilt clutches is in good condition; if not, remove and regrease with Kernite LUBE-K-AC (p/n 104034/801) to ensure smooth and even movement of the mirror.

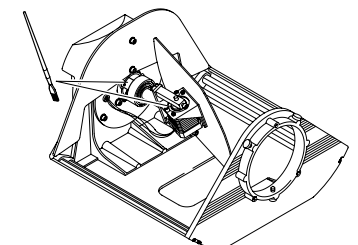

8 TROUBLESHOOTING

PROJECTOR DOES NOT LIGHT UP			FAULTS
ELECTRONICS NOT WORKING			
PROJECTION FAULTY			
REDUCED BRIGHTNESS			
POSSIBLE CAUSES		CHECKS AND REMEDIES	
●		No electrical power supply.	Check that power is available at the mains socket and/or that fuses are intact.
●	●	Lamp expended or faulty.	Change lamp (see instructions).
●		Signal transmission cable short-circuiting or disconnected.	Change cables.
●		Address codes incorrect.	See projector coding instructions.
●		Defect in electronic circuits.	Contact an authorized technician.
●	●	Lenses broken.	Contact an authorized technician.
●	●	Dust or grease deposit.	Clean (see instructions).

9 TECHNICAL DATA

ELECTRICAL MECHANICAL SPECIFICATIONS

Power supplies available

- 220 - 240V 50Hz
- 200 - 220V 60Hz
- 200 50Hz
- 200 60Hz
- 260 50Hz

The projector is designed to operate at the mains frequency and voltage given on the electrical data label on the base of the appliance.

Lamp

Metal halide with special built-in power supply.

- Type HMI 575W
 - Cap SFC 10-4
 - Colour temperature 6000 K
 - Luminous flux 49000 lm
 - Average life 750 h
- Type HMI 1200W
 - Cap SFC 15,5-6
 - Colour temperature 6000 K
 - Luminous flux 110000 lm
 - Average life 750 h

Power consumption

- Version HMI 575
 - 1500 VA at 220V 50Hz
- Version HMI 1200
 - 3000VA at 220V 50Hz

Motors

N. 6 microstepping motors with full microprocessor control.

OPTICAL SYSTEM

Main optical unit

- Base in diecast aluminium
- Twin lens condenser
- High luminous efficiency spherical reflector.

Lens units

- Standard: 1:2,5/250 mm
- Optional: 1:3/150 mm

CONTROL SYSTEMS

Channels

N. 4 control channels.

Inputs

TIGER SCAN is designed to accept analog or digital control signals from controllers or computers.

- RS232/423(PMX) or DMX 512 digital serial input
- 0-10V analog input

MIRROR HEAD

- Head rotatable through 360° on projector housing.
- Graduated scale for easy and accurate positioning.
- Anchorage for safety wire.
- Ultra high luminous efficiency mirror.

Movement

- Produced by two microprocessor controlled microstepping motors.
- Infinitely variable speed of rotation. Maximum values:
 - PAN = 0.4 sec (150°)
 - TILT = 0.3 sec (110°)
- Continuous and uniform movement. Resolution:
 - PAN = ±0.3° (150°)
 - TILT = ±0.2° (110°)

CONSTRUCTION FEATURES

Safety devices

- Power shuts off automatically in the event of overheating or cooling system failure.
- Power shuts off automatically when cover is opened.

Cooling

Forced ventilation cooling system using axial flow fans.

Housing

- Extruded diecast aluminium.
- Epoxy powder coated finish.

Mounting

- Steel bracket with epoxy powder coated finish.
- Six installation positions 25mm (4") apart (HMI 1200 version only).
- Bracket adjustable through 100°.
- Anchorage for safety wire.

Operating position

Will function in any position.

Weights and dimensions

- HMI 575: 25 kg. (55 lbs)
- HMI 1200: 35.5 kg. (78 lbs 2 ozs)
- Mirror head: 3.1 kg. (6 lbs 13 ozs)

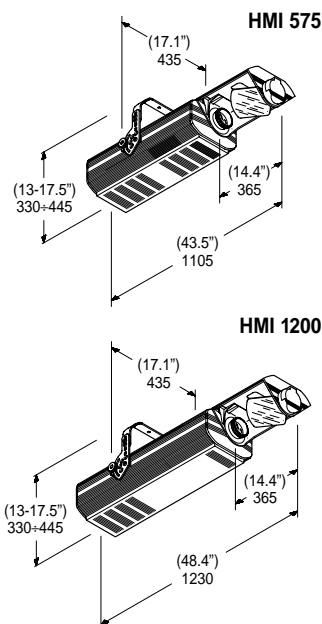

10 WIRING DIAGRAM

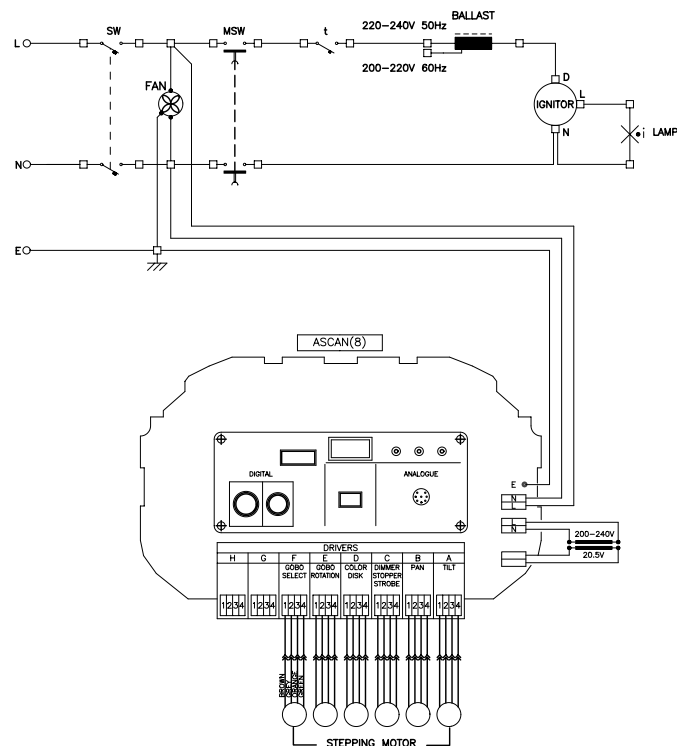

The specifications published in this manual are not binding, and may be revised or updated at any time by Clay Paky without notice in the interests of improving product quality.

The products referred to in this manual comply with EC Directives on:

- Low Voltage 73/23
- Electromagnetic Compatibility 89/336

ENGLISH